

SX Submersible drainage pumps

Reseller Series



For pumping clean and dirty water

These small compact stainless steel submersibles from ITT Flygt offer performance and economy and are the perfect choice for a wide range of different applications, including:

- Routine and general maintenance of basements, public parking areas, garages and cellars;
- Drainage of underpasses, yards, tanks, reservoirs, ditches and trenches;
- Pump-out of dirty water from sinks, washing machines and wash basins;
- Transferring raw or clean water;
- Emergency standby in case of flooding;
- Rainwater collection pump for small garden irrigation;
- Small fountains or landscape waterfalls;
- Shallow sumps with clean or dirty water.

Features

- Corrosion resistant construction prevents "stuck" impellers due to rust buildup;
- Dry motor needs no cooling oil, eliminating the possibility of environmental contamination while making service easier;
- SX 2, SX 3 feature strong, corrosion resistant, thermoplastic body parts, impeller, suction plate with outer stainless steel motor jacket;
- Other larger models available.

SX Submersible drainage pumps

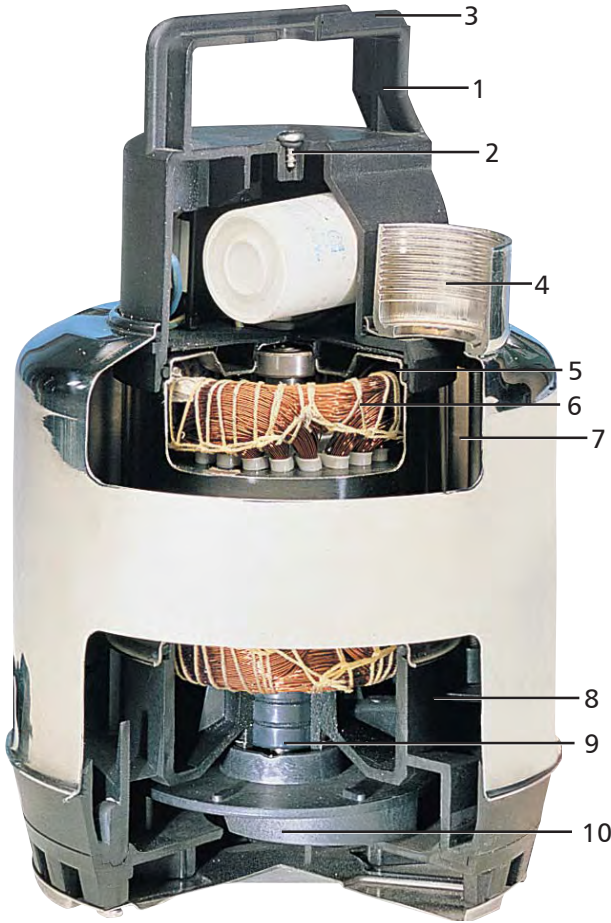

- 1 Fiberglass reinforced lifting handle;
- 2 Inspection plug to check for water intrusion;
- 3 Float switch cable holder;
- 4 Strong, stainless steel hose connection, 1½" NPT threads;
- 5 Motor housing with enclosed upper bearing and seamless stainless steel outer jacket;
- 6 Class "B" insulated motor operates in air rather than oil, reducing motor drag for improved efficiency while eliminating the possibility of environmental contamination;
- 7 Stainless steel outer jacket;
- 8 Pump body parts of strong, fiberglass reinforced noryl;
- 9 Triple lip seal for added protection;
- 10 Stainless steel shaft, prevents corrosion and rust buildup.

	SX 2	SX 3
Rated output hp	0.33	0.75
Max. head ft	21	34
Max. flow USGPM	35	58
Full load Amps		
1-phase 115V	2.8	6.8
230V	1.4	3.5
Discharge connection	1½" NPT	
Max. temp. of pumped liquid	40°C	
Cable SOW	20 ft	

All models "direct plug-in" available with or without automatic float switch.

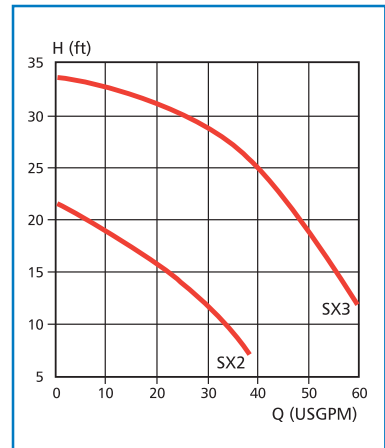
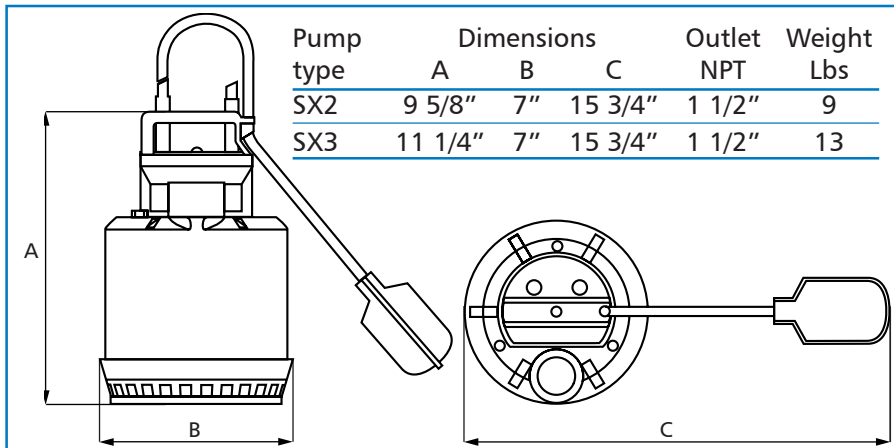
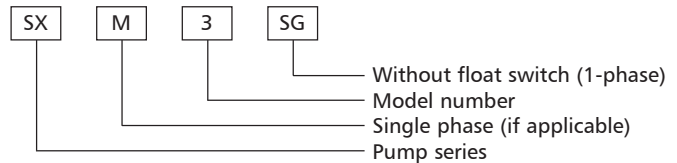

LOOK FOR FLYGT RESELLER PRODUCTS AT OUR REGISTERED RESELLER, REPAIR SHOP, OR AUTHORIZED DISTRIBUTOR.

Coquitlam, BC, (604) 941-6664 • Calgary, AB, (403) 279-8371 • Edmonton, AB, (780) 489-1961 • Saskatoon, SK, (306) 933-4849
 Winnipeg, MB, Tel.: (204) 235-0050 • Concord, ON, (905) 760-7530 • Ottawa, ON, Tel.: (613) 225-9600 • Sudbury, ON, (705) 560-2141
 Thunder Bay, ON, Tel.: (807) 625-9960 • Pointe-Claire, QC, (514) 695-0133 • Québec, QC, Tel.: (418) 667-1694 • Val d'Or, QC, (819) 825-0792
 Moncton, NB, Tel.: (506) 857-2244 • Halifax, NS, (902) 450-1177 • St. John's, NL, Tel.: (709) 722-6717



www.flygt.ca